

No.	Item	Symbol	Unit	Specification	No.	Item	Symbol	Unit	Specification
1	Drive	-	-	3 ϕ 220 VAC	13	Rotor Inertia	Jm	kg-cm ²	1.64 \pm 10%
2	Cooling Method	-	-	Totally Enclosed	14	Rated Power Rate	Q-R	Kw/s	34.74
3	Exciting Method	-	-	Permanent Magnet	15	Resistance	Ra	Ω	1.48 \pm 10%/2 ϕ
4	Resolution	-	-	23 bit-INC	16	Inductance	L	mH	10.1 \pm 10% / 2 ϕ
5	Rated Output	P-R	W	750	17	Mech. Time Constant	Tm	ms	1.05
6	Rated Torque	T-R	N-m	2.39	18	Elect. Time Constant	Te	ms	6.82 \pm 10%
7	Max. Torque	T-max	N-m	7.16	19	Insulation Class	-	-	Class F
8	Rated Speed	N-R	rpm	3000	20	Operation Temp.	T	$^{\circ}$ C	0~40
9	Rated Current	I-R	A	4.3	21	Operation Humd.	RH	%	<80
10	Max. Current	I-max	A	14	22	Storage Temp.	T	$^{\circ}$ C	-20 $^{\circ}$ ~60 $^{\circ}$
11	Torque Constant	Kt	N-m/A	0.56	23	Storage Humd.	RH	%	<80
12	Voltage Constant	Ke	V/k rpm	37.3 \pm 10%	24	Weight	W	kgw	4.1

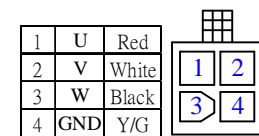

Motor Connection

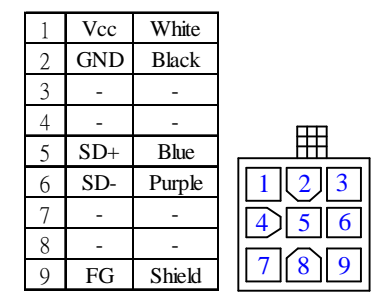

Encoder Connection

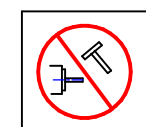

Do not Hammer!

Name Plate for Notice

AC SERVO MOTOR
 Model: JSMA-PBC08A3KB
 Pr: 0.75 KW ; Nr: 3000 rpm
 Ir: 4.3 A , Tr: 2.39 N-m
 NO.
TECO ELECTRIC & MACHINERY CO., LTD.
 MADE IN TAIWAN

Note:
 Motor to be IP67(excluding the shaft opening & connectors)

PIN:AMP 770835-1
 HOUSING:AMP 172169-1

PIN:AMP 170360-1
 HOUSING:AMP 172167-1

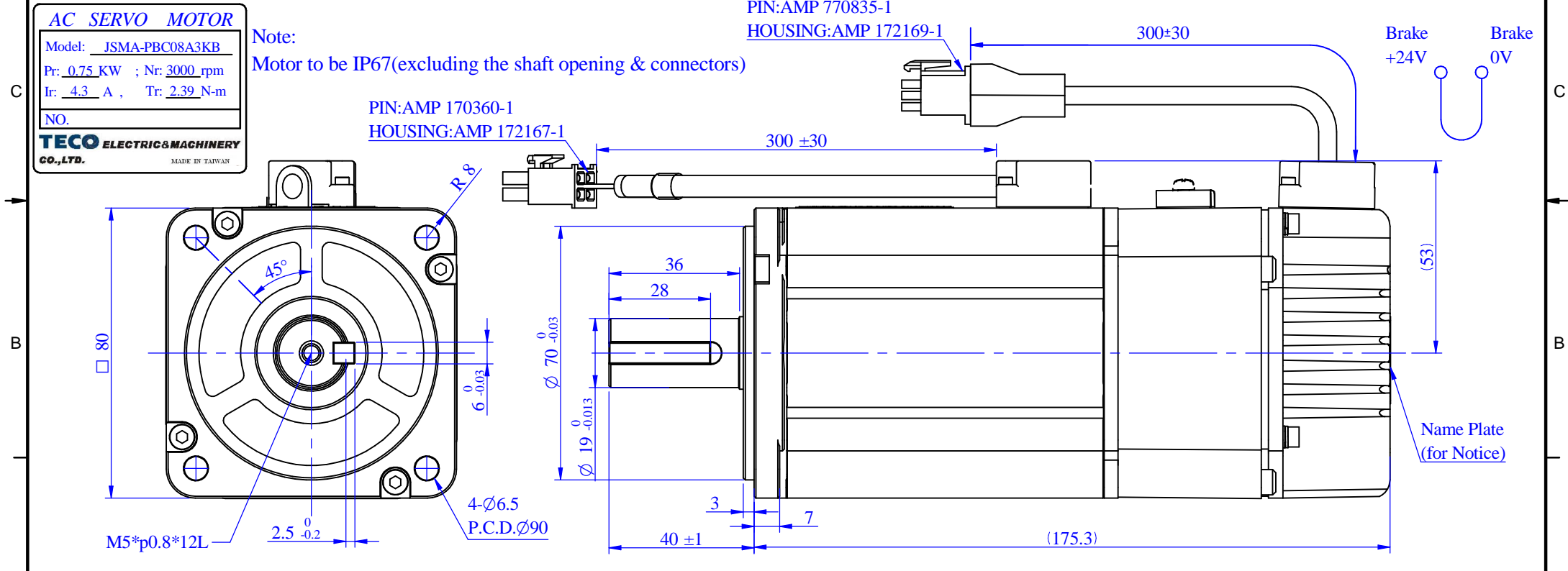

STANDARD TOLERANCE					APVD		SCALE	2/3	UNIT	mm	NAME	Servo Motor Outline Drawing	
X	\pm 0.5				CHKD						TITLE	JSMA-PBC08A3KB	
.X	\pm 0.2				CHKD		3RD .A.P						
.XX	\pm 0.05				DWN	Leon	04-08-'16			Dept. Design	DWG.NO.	D01E08751C3BZ3D01	
ANGLE	\pm 30'												
MATERIAL		REV	DESCRIPTION	SIGNATURE	DATE	SIGNATURE	DATE						